



# Link Budget Analysis: Digital Modulation, **Part 2**

[www.AtlantaRF.com](http://www.AtlantaRF.com)



**Atlanta RF**

Services, Software & Designs

# Presentation Content

## Link Budget Analysis: Digital Modulation, **Part 2**

1. FSK: Frequency Shift Keying.
  - A. Basis of Operation.
2. Binary FSK:
  - A. Basis of Operation.
  - B. Typical BFSK Modulated Signal.
  - C. Implementation of BFSK.
  - D. Power Spectral Density of BFSK.
3. MFSK:  $M_{\text{-ary}}$  Frequency Shift Keying:
  - A. Power Spectral Density of MFSK.
  - B. Error Probability of MFSK.
  - C. Probability of Symbol Error: MFSK.
4. Frequency Shift Keying Issues.
5. Non-coherent FSK:
  - A. Overview.
  - B. Probability of Bit Error.
6. Bandwidth Efficiency of MFSK.
7. C/N for M-FSK at BER values.
8. MSK: Minimum Shift Keying:
  - A. Overview & Basis of Operation.
  - B. MSK Waveforms: Example.
  - C. Power Spectral Density of MSK.
  - D. Features of Minimum Shift Keying.
  - E. Error performance of QPSK, Offset-QPSK and MSK.
  - F. Advantages of QPSK and MSK.
9. GMSK: Gaussian MSK:
  - A. Basis of Operation.
  - B. Block Diagram for GMSK.
  - C. BER for GMSK.
  - D. GMSK Power Spectral Density.
  - E. Applications for GMSK modulation.
10. Summary: Digital Modulation, Part 2

Refer to background material in Atlanta RF's presentations titled:

1. 'Link Budget – Getting Started' and
2. 'Link Budget: Digital Modulation Part 1'

which can be downloaded from our website: [www.AtlantaRF.com](http://www.AtlantaRF.com).

**Atlanta RF**

Services, Software & Designs

# FSK: Frequency Shift Keying

## Constant envelope modulation

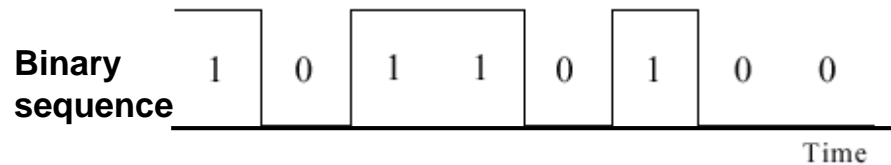

(b) FREQUENCY-SHIFT KEYING (FSK) SIGNAL

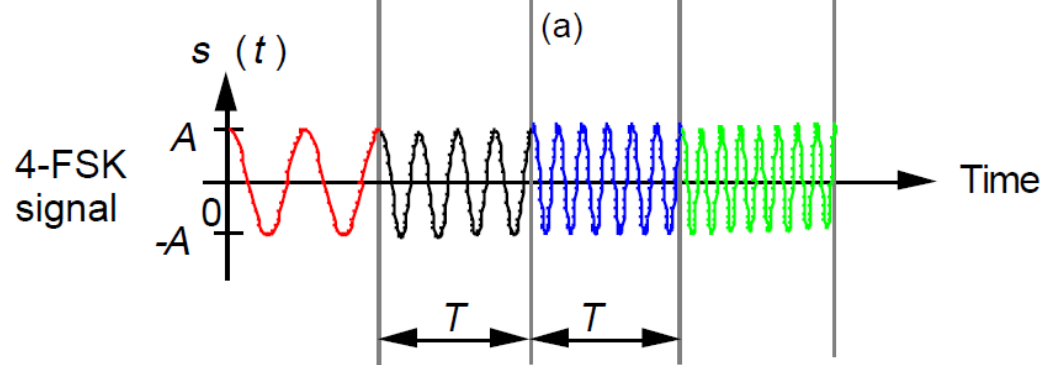
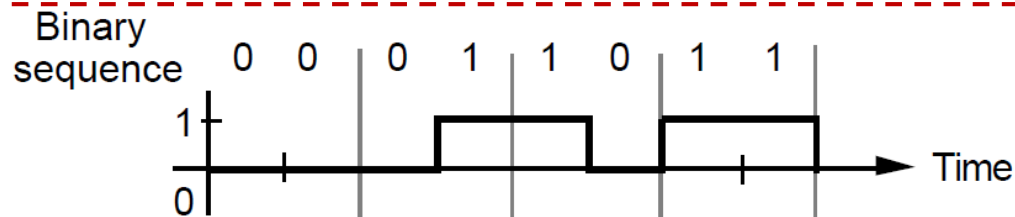
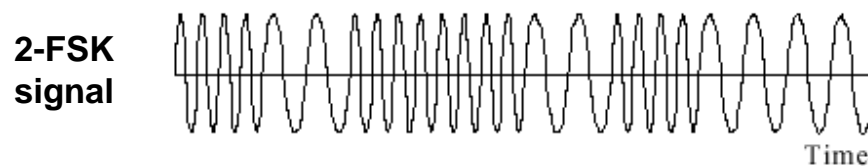

# FSK: Frequency Shift Keying

## Basis of operation

1. When the baseband signal modulates the frequency of the carrier signal, the process is called “[frequency modulation](#)”. For digital baseband signals, it is called “[Frequency Shift Keying](#)”: FSK .
2. Frequency-Shift Keying (FSK) is a form of [digital modulation](#) that represents [digital data](#) solely through discrete variations in the [frequency](#) of a [carrier signal](#).
3. In FSK, the instantaneous frequency (or tone) of a constant-amplitude carrier signal is changed between two (for BFSK) or more (for  $M_{\text{ary}}$ FSK) values by the baseband digital message signal:  $m(t)$ , at the beginning of each signal interval:  $T_s$  , to represent symbol states (a pair or trio of bits). The carrier signal’s amplitude remains constant. The  $M_{\text{ary}}$ FSK transmitted signal:  $s(t)$  is:

$$S_{MFSK}(t) = \sqrt{\frac{2E_s}{T_s}} \cos\left(\frac{\pi}{T_s}(n_c + i)t\right) = \sqrt{\frac{2E_s}{T_s}} \cos\left(2\pi\left(f_c + \frac{i}{2T_s}\right)t\right), 0 < t < T_s \text{ for } i = 1, 2, 3 \dots M$$

where :  $f_c = n_c/(2T_s)$  and  $n_c = \text{Fixed integer}$ .  $E_s = E_b \log_2 M$ ;  $T_s = T_b \log_2 M$

4. In  $M_{\text{ary}}$  FSK, the minimum frequency spacing to maintain orthogonality between carriers is:  $2\Delta f_{\text{min}} = R_s/2 = 1/(2T_s)$  for **coherent** detection, and  $2\Delta f_{\text{min}} = R_s = 1/T_s$  for **non-coherent** detection.
5. FSK is not very susceptible to noise, since the voltage spikes caused by noise affects the carrier’s amplitude, but do not affect the carrier’s frequency.

# BFSK: Binary Frequency Shift Keying

## Basis of Operation

- For binary FSK (BFSK), the digital message state for a binary '1' and for a binary '0' are represented by two different frequencies slightly offset from the carrier's frequency:  $f_c$  with constant amplitude. By convention, the higher carrier frequency is called the 'mark' frequency (or high tone:  $f_H = f_c + \Delta f$ ) and the lower carrier frequency is the 'space' frequency (or low tone:  $f_L = f_c - \Delta f$ ). If  $T_b$  indicates the duration of one information bit, the two time-limited frequency modulated carrier signals can be expressed as:

$$S_{BFSK}(t) = \begin{cases} S_H(t) = A_c \cos(2\pi f_1 t) = \sqrt{\frac{2E_b}{T_b}} \cos(2\pi f_c + 2\pi \Delta f) t, & 0 \leq t \leq T_b \text{ for binary 1} \\ S_L(t) = A_c \cos(2\pi f_2 t) = \sqrt{\frac{2E_b}{T_b}} \cos(2\pi f_c - 2\pi \Delta f) t, & 0 \leq t \leq T_b \text{ for binary 0} \end{cases}$$

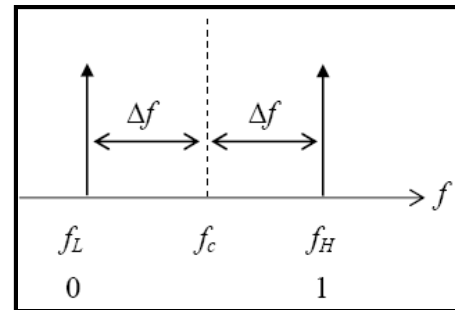

Frequency domain  
for Binary FSK

where :  $f_c = 0.5(f_H + f_L) = m/(2T_b)$ ;  $\Delta f = 0.5(f_H - f_L) = n/(2T_b)$

- Map bits into carrier's signal frequency: When binary "1", send carrier signal frequency:  $f_c + \Delta f$ ; when binary "0", send carrier signal frequency:  $f_c - \Delta f$ . The demodulator looks for signal power around frequency:  $f_c + \Delta f$  or  $f_c - \Delta f$ .
- Each frequency state lasts for a single bit period:  $T_b$ , and then may be replaced by either frequency state:  $f_{\text{mark}}$  or  $f_{\text{space}}$ , Hertz.

# Typical Binary FSK Modulated Signal

## BFSK waveforms shown in the time domain

Binary bit '1' and '0' are represented by two different frequencies slightly offset from the carrier frequency.

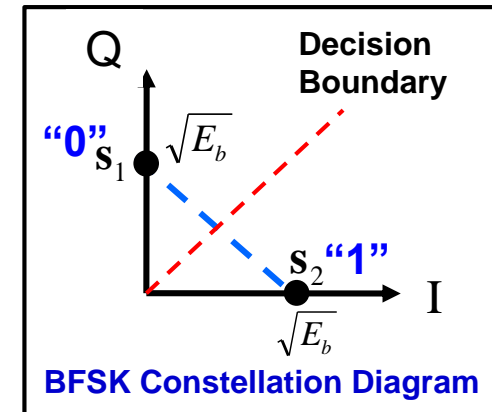
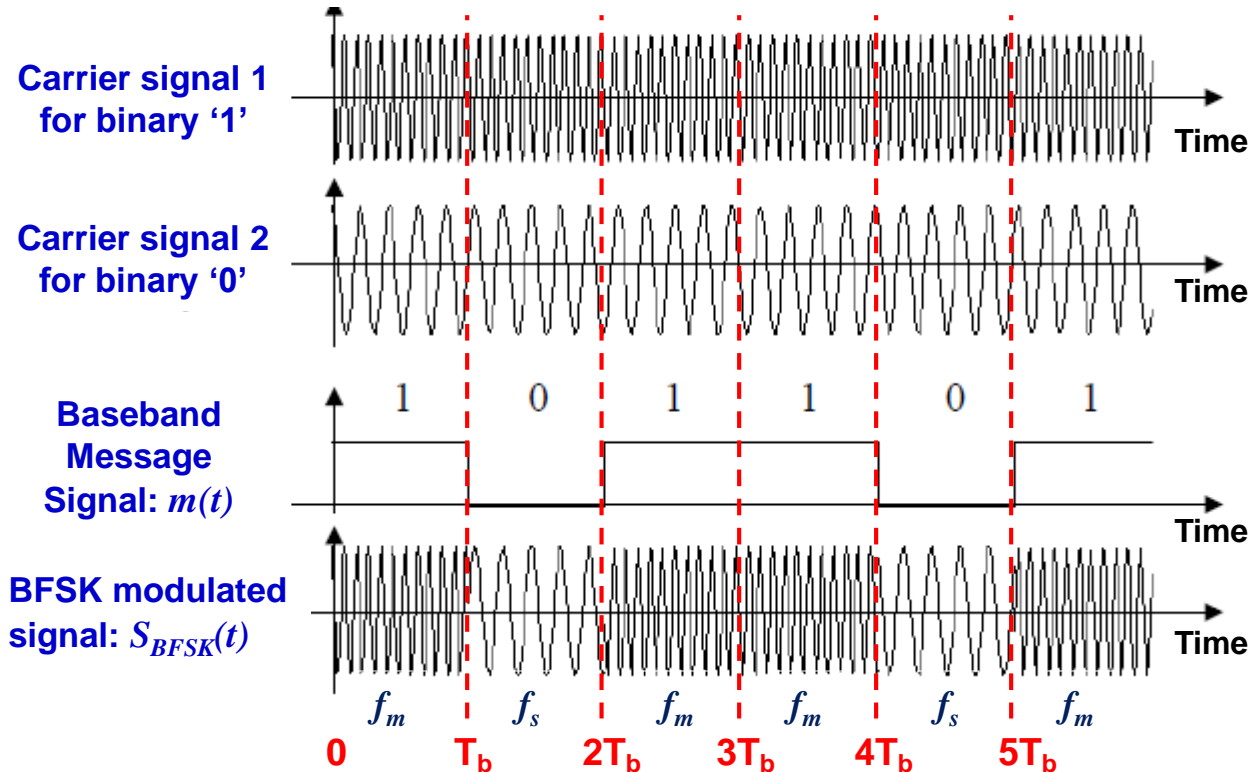

where:  $f_s$  = Low 'space' carrier frequency =  $f_o - \Delta f$ , hertz .....for a Logic 0.  
 $f_m$  = High 'mark' carrier frequency =  $f_o + \Delta f$ , hertz .....for a Logic 1.

# Implementation of Binary FSK

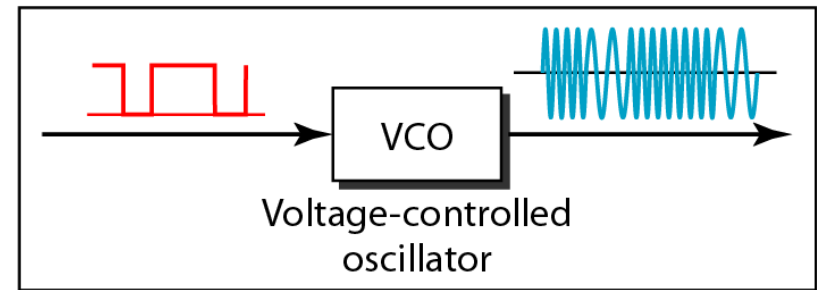
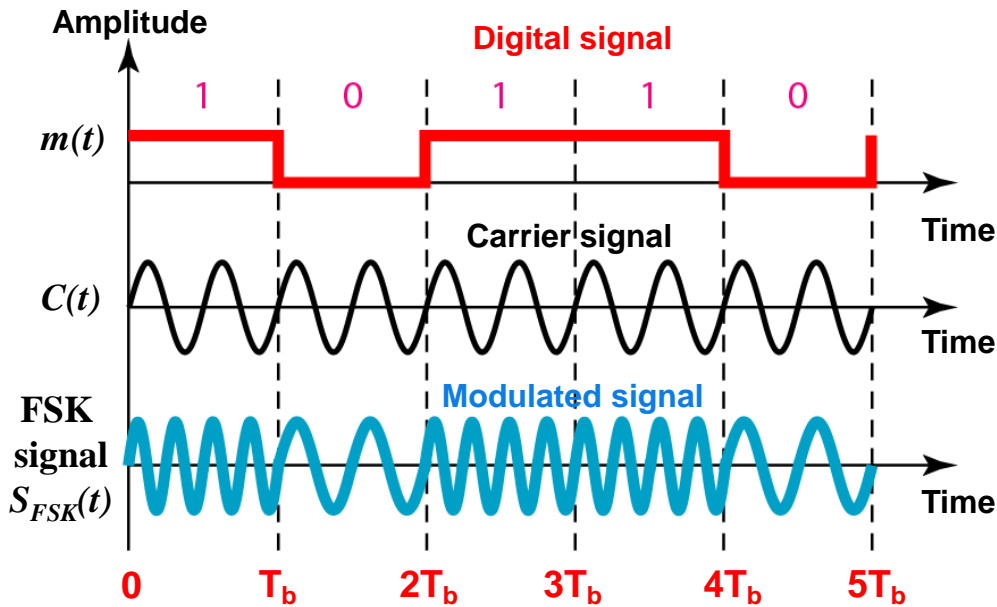

Data

0 1 1 1 0 0 1 1 1 1 0 1 1 0 0 0 0 0 1 1

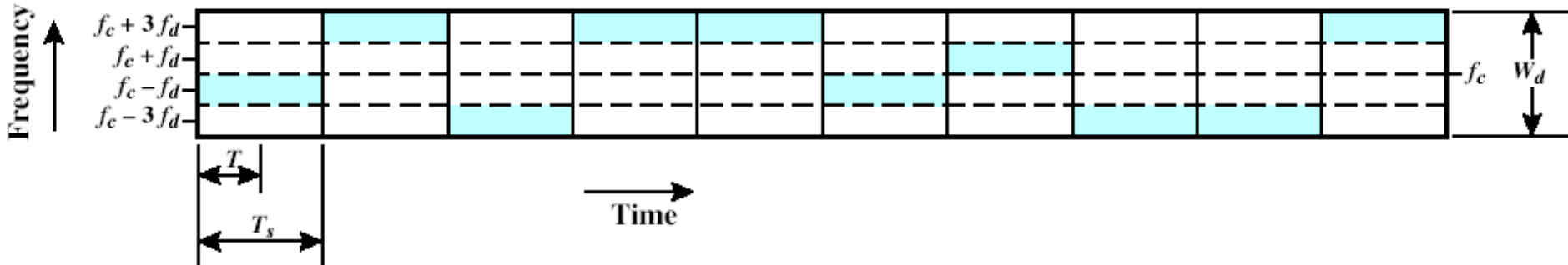

# Bandpass Power Spectral Density of Binary FSK

Assumes baseband rectangular pulse stream: 

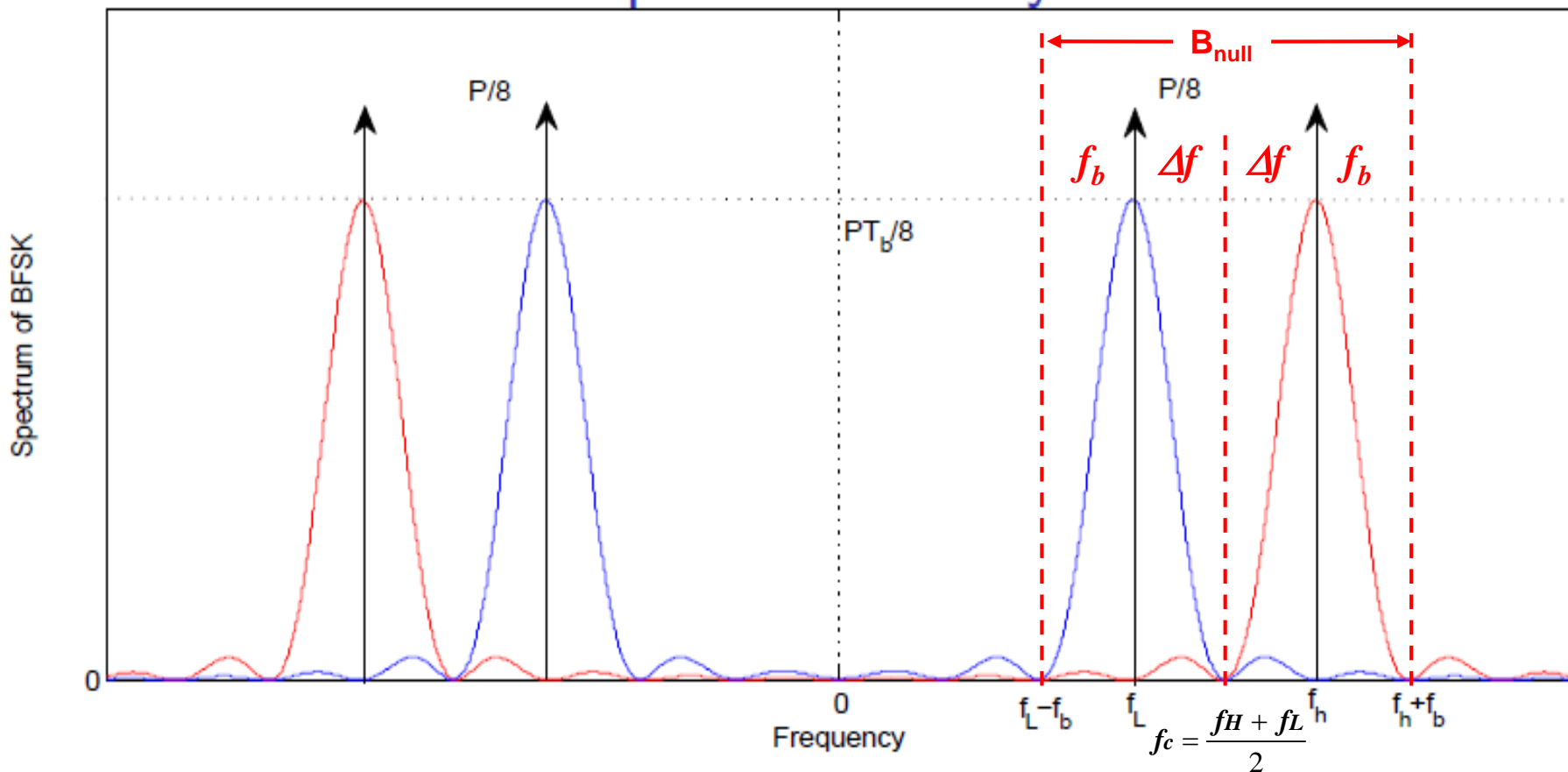

- Energy per bit:  $E_b = PT_b$ , watt-second.
- The Null-to-Null RF transmission bandwidth for Binary FSK is:
  - $B_{null} = (f_h + f_b) - (f_L - f_b) = (f_h - f_L) + 2f_b = 2\Delta f + 2f_b = 2(\Delta f + R_b) = \text{Carson's Rule}$ .
- BFSK bandwidth with 90% of signal power:  $B_{90\%} = 1.23R_b$ .
- BFSK bandwidth with 99% of signal power:  $B_{99\%} = 2.12R_b$ .

**Atlanta RF**

Services, Software & Designs



# Bandpass Power Spectral Density of $M_{\text{ary}}$ FSK

Assumes baseband rectangular pulses: 

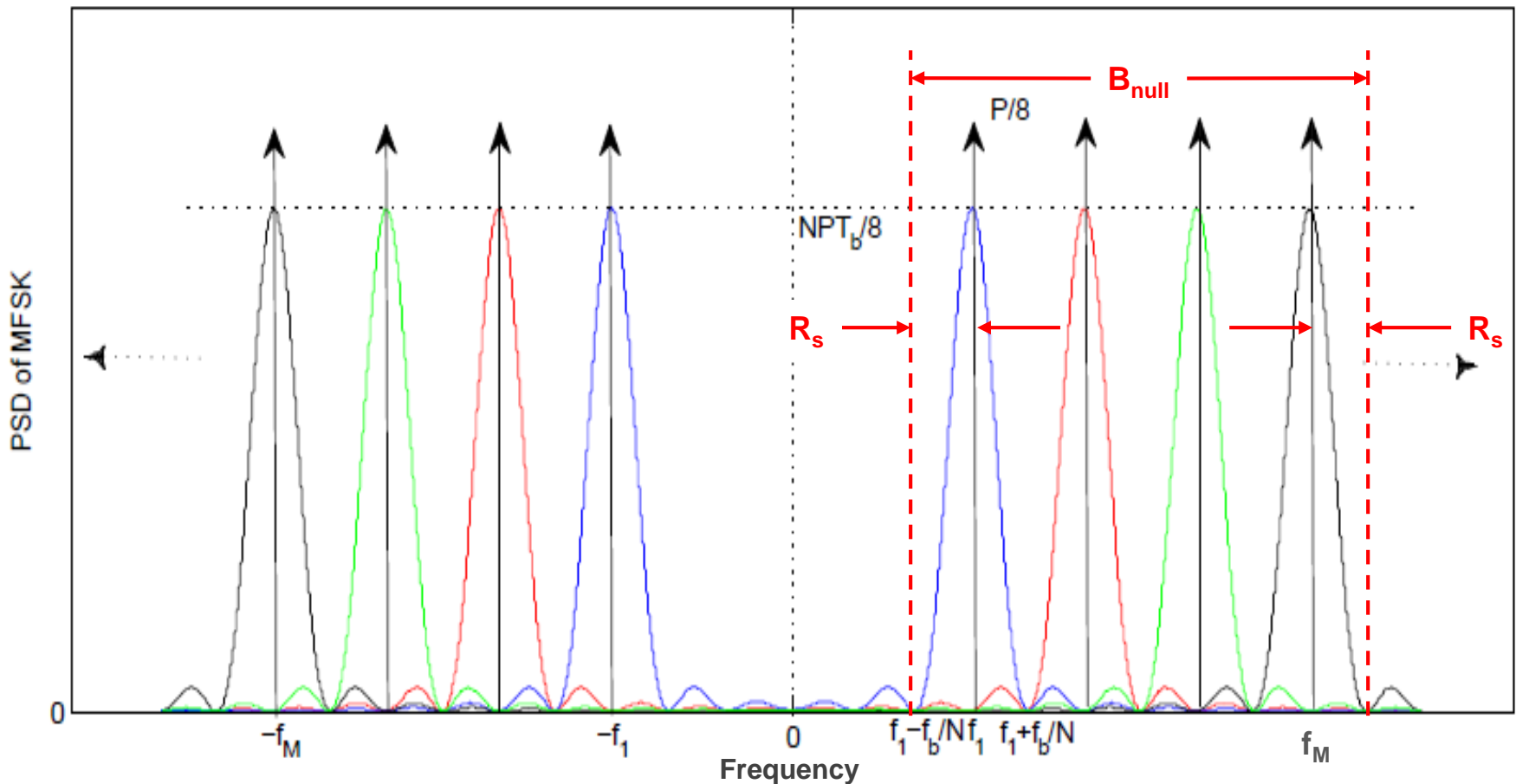

- The Null-to-Null RF transmission bandwidth for MFSK is:
  - $B_{\text{null}} = R_s + (M - 1)(f_2 - f_1) + R_s = 2R_s + (M - 1) 2\Delta f$ , where:  $R_s = f_b/N$ ,  $N = \log_2 M$ .
  - For coherently detected M-FSK:  $2\Delta f_{\text{min}} = R_s/2$ . Then,  $B_{\text{null}} = (M + 3)R_s/2$ , Hertz.
  - For non-coherently detected M-FSK:  $2\Delta f_{\text{min}} = R_s$ . Then,  $B_{\text{null}} = (M + 1) R_s$ , Hertz.

# Error Probability for M-ary Frequency Shift Key

## In an Additive White Gaussian Noise (AWGN) channel

1. Modulated carrier signal for Multi-Level FSK modulation:

$$S_{MFSK}(t) = \sqrt{\frac{2E_s}{T_s}} \cos\left(\frac{\pi}{T_s}(n_c + i)t\right) = \sqrt{\frac{2E_s}{T_s}} \cos\left(2\pi\left(f_c + \frac{i}{2T_s}\right)t\right), 0 < t < T_s \text{ for } i=1,2,3\dots M$$

where  $f_c = n_c/(2T_s)$  and  $n_c = \text{Fixed integer}$ .  $E_s = E_b \log_2 M$ ;  $T_s = T_b \log_2 M$

2. Probability of **symbol error** for coherently detected **M-ary FSK**:

$$P_{se,MFSK} \leq (M-1)Q\left(\sqrt{\frac{E_s}{N_o}}\right) \leq \frac{1}{2}(M-1)\text{erfc}\left(\sqrt{\frac{E_s}{2N_o}}\right) \leq \frac{1}{2}(M-1)\text{erfc}\left(\sqrt{\frac{(\log_2 M) E_b}{2 N_o}}\right)$$

where  $k = \log_2 M$ , bits / symbol.

3. Probability of **bit error** (BER) for coherently detected orthogonal **M-ary FSK**:

$$P_{be,MFSK} = \frac{M/2}{M-1} P_{se,MFSK}$$

4. Probability of **bit error** for coherently detected orthogonal **Binary FSK** (M= 2):

$$P_{be,BFSK} = Q\left(\sqrt{\frac{E_b}{N_o}}\right) = \frac{1}{2}\text{erfc}\left(\sqrt{\frac{E_b}{2N_o}}\right)$$

# Error Probability for M-ary Frequency Shift Key In an Additive White Gaussian Noise (AWGN) channel

- The average probability of bit error (BER) for Multi-Level Frequency Shift Keying (M-FSK) using coherent detection can be approximated by:

$$P_{be,MFSK} \leq \frac{M}{2} Q\left(\sqrt{\frac{E_s}{N_o}}\right) \leq \frac{M}{4} \operatorname{erfc}\left(\sqrt{\frac{E_s}{2N_o}}\right) \leq \frac{M}{4} \operatorname{erfc}\left(\sqrt{\frac{(\log_2 M) E_b}{2 N_o}}\right)$$

M	k	Probability of Bit Error (BER): $P_{be}$	M	k	Probability of Bit Error (BER): $P_{be}$
4	2	$P_{be,4FSK} \leq \operatorname{erfc}\left(\sqrt{\frac{E_b}{N_o}}\right)$	8	3	$P_{be,8FSK} \leq 2\operatorname{erfc}\left(\sqrt{\frac{3 E_b}{2 N_o}}\right)$
16	4	$P_{be,16FSK} \leq 4\operatorname{erfc}\left(\sqrt{\frac{2E_b}{N_o}}\right)$	32	5	$P_{be,32FSK} \leq 8\operatorname{erfc}\left(\sqrt{\frac{5E_b}{2N_o}}\right)$
64	6	$P_{be,64FSK} \leq 16\operatorname{erfc}\left(\sqrt{\frac{3E_b}{N_o}}\right)$	128	7	$P_{be,128FSK} \leq 32\operatorname{erfc}\left(\sqrt{\frac{7E_b}{2N_o}}\right)$
256	8	$P_{be,256FSK} \leq 64\operatorname{erfc}\left(\sqrt{\frac{4E_b}{N_o}}\right)$	512	9	$P_{be,512FSK} \leq 128\operatorname{erfc}\left(\sqrt{\frac{9E_b}{2N_o}}\right)$

# Probability of Bit Error (BER): Coherent M<sub>ary</sub> FSK

## In an Additive White Gaussian Noise (AWGN) channel

Probability of Symbol Error for coherently detected Multi -Level FSK :

$$P_{se,MFSK} \leq \frac{1}{2}(M - 1)erfc\left(\sqrt{\frac{E_s}{2N_o}}\right) \leq \frac{1}{2}(M - 1)erfc\left(\sqrt{\frac{(\log_2 M) E_b}{2 N_o}}\right)$$

where :  $k = \log_2 M$ , bits / symbol.

k, bits/ symbol =	1	2	3	4	5	
M signal levels =	2	4	8	16	32	
E <sub>b</sub> /N <sub>o</sub> , dB	E <sub>b</sub> /N <sub>o</sub>	Probability of Bit Error:		P <sub>be,MFSK</sub>		
0	1.000	0.1587	0.1573	0.1665	0.1820	0.2028
1	1.259	0.1309	0.1126	0.1039	0.0993	0.0969
2	1.585	0.1040	0.0750	0.0584	0.0472	0.0390
3	1.995	0.0789	0.0458	0.0288	0.0189	0.0127
4	2.512	0.0565	0.0250	0.0121	0.0061	0.0032
5	3.162	0.0377	0.0119	0.0041	0.0015	5.60E-04
6	3.981	0.0230	0.0048	0.0011	2.64E-04	6.51E-05
7	5.012	0.0126	0.0015	2.11E-04	3.02E-05	4.45E-06
8	6.310	0.0060	3.82E-04	2.71E-05	2.03E-06	1.56E-07
9	7.943	0.0024	6.73E-05	2.10E-06	6.93E-08	2.35E-09
10	10.000	7.83E-04	7.74E-06	8.64E-08	1.02E-09	1.23E-11
11	12.589	1.94E-04	5.23E-07	1.59E-09	5.13E-12	1.69E-14
12	15.849	3.43E-05	1.80E-08	1.07E-11	6.66E-15	0.0E+00
13	19.953	3.97E-06	2.67E-10	2.04E-14	0.0E+00	0.0E+00
14	25.119	2.70E-07	1.36E-12	0.0E+00	0.0E+00	0.0E+00
15	31.623	9.36E-09	1.78E-15	0.0E+00	0.0E+00	0.0E+00
16	39.811	1.40E-10	0.0E+00	0.0E+00	0.0E+00	0.0E+00

Probability of bit error (BER) for coherently detected M-ary FSK :

$$P_{be,MFSK} = \frac{M / 2}{M - 1} P_{se,MFSK}$$

Probability of Bit Error (BER) for Binary FSK :

$$P_{be,BFSK} = \frac{1}{2} erfc\left(\sqrt{\frac{E_b}{2N_o}}\right)$$

The complementary error function: 'erfc' is built into most spreadsheet software programs, like: Excel.

**Atlanta RF**

Services, Software & Designs

# Probability of Bit Error (BER): Coherent M-FSK

Probability of Symbol Error for coherently detected M-FSK :

$$P_{se,MFSK} \leq \frac{1}{2}(M-1)erfc\left(\sqrt{\frac{E_s}{2N_o}}\right) \leq \frac{1}{2}(M-1)erfc\left(\sqrt{\frac{(\log_2 M) E_b}{2 N_o}}\right)$$

Probability of Bit Error for MFSK :

$$P_{be,MFSK} = \frac{M/2}{M-1} P_{se,MFSK}$$

Probability of Bit Error for Binary FSK :

$$P_{be,BFSK} = Q\left(\sqrt{\frac{E_b}{N_o}}\right) = \frac{1}{2}erfc\left(\sqrt{\frac{E_b}{2N_o}}\right)$$

Probability of Bit Error: Pbe,MFSK

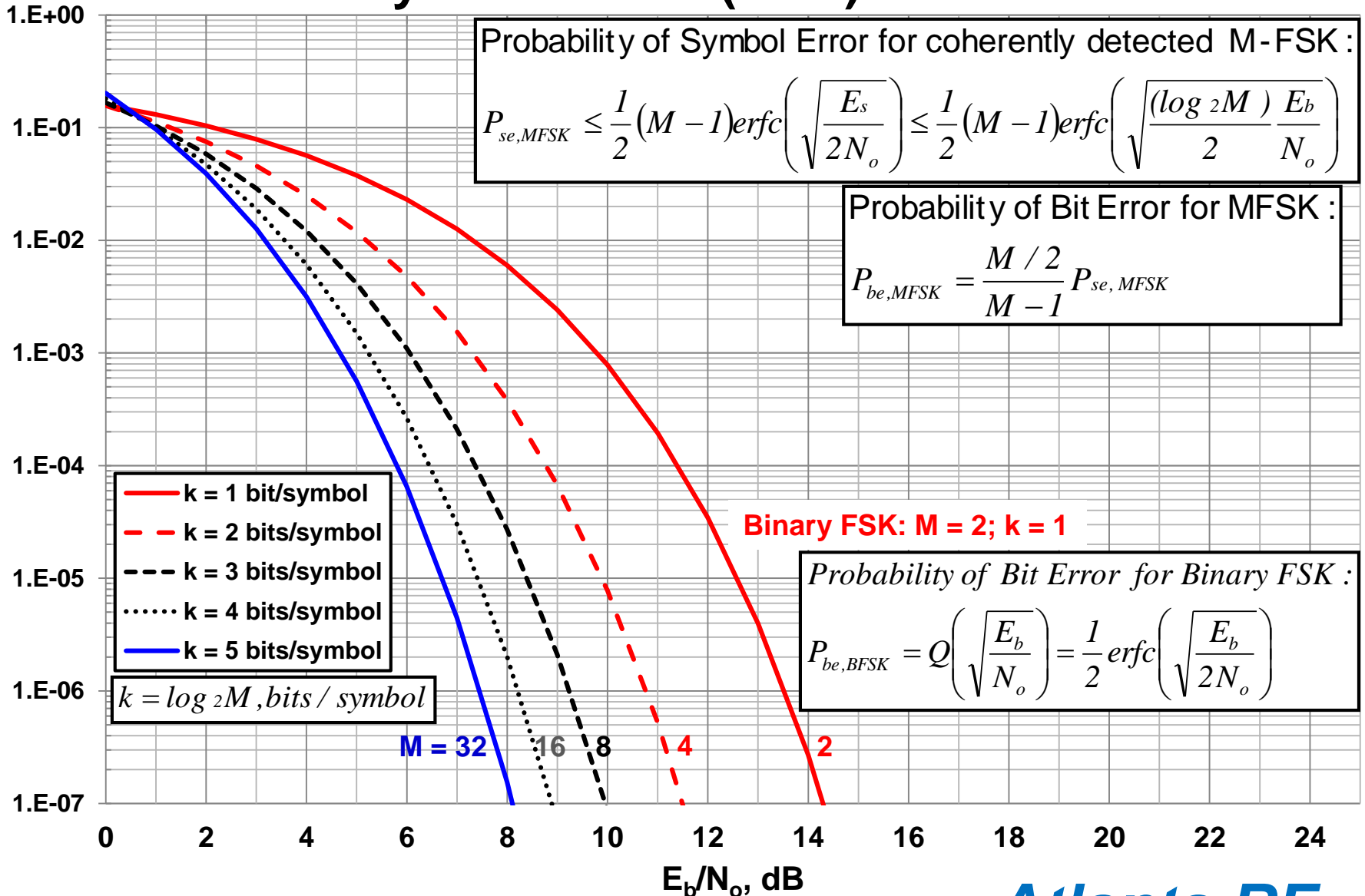

$E_b/N_o$  = Signal energy per bit over Noise density per bit.

# Frequency Shift Keying Issues

## 1. Advantages of FSK:

- A. FSK is ideally a constant envelope modulation; hence, more power-efficient class-C non-linear Power Amplifiers can be used in the transmitter.
- B. FSK is more bandwidth efficient than ASK.
- C. Reasonably simple modulation and demodulation schemes.

## 2. Disadvantages of FSK:

- A. The difference between coherent FSK detection and non-coherent FSK detection is not significant for higher FSK levels.
- B. The extra hardware required for coherent FSK detection is hence hard to justify.
- C. Coherent FSK is **not often used** in practice due to the difficulty (and cost) in generating two reference frequencies close together at the receiver.

FSK Demodulation (Coherent)

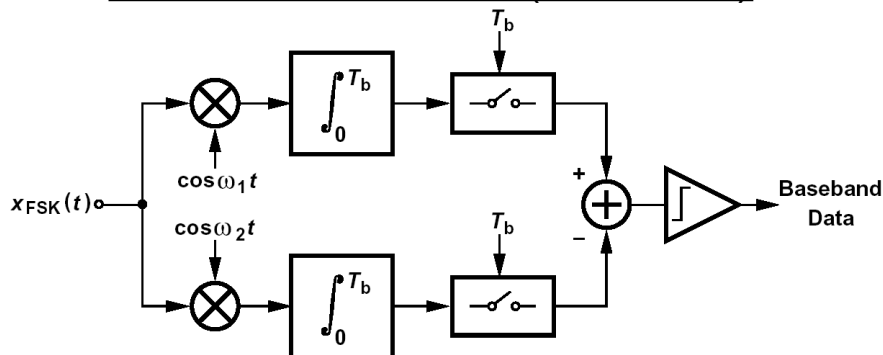

FSK Demodulation (Non-Coherent)

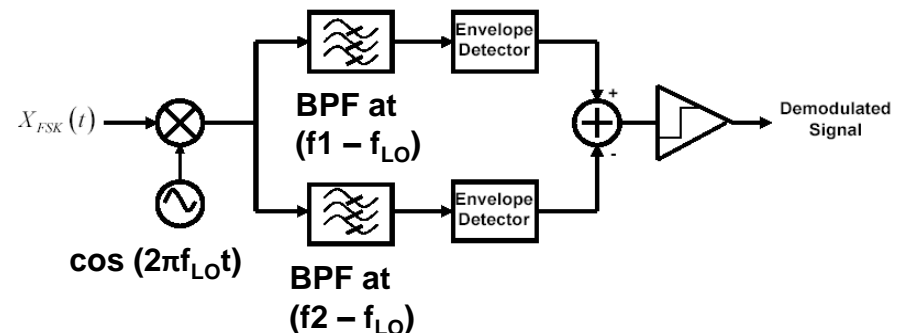

# Noncoherent FSK

## Overview

1. The noncoherent FSK requires, at most, only 1 dB more  $E_b/N_0$  than that for coherent FSK for probability of bit error:  $P_b < 10^{-4}$  (See next slide for BER).
2. The noncoherent FSK demodulator is considerably easier to build since coherent reference signals need not be generated.
3. Coherent FSK signals can be noncoherently demodulated to avoid the carrier recovery.
4. Noncoherently generated FSK can only be noncoherently demodulated.
5. Both cases are referred to 'noncoherent FSK'.
6. In both cases, the demodulation problem becomes a problem of detecting signals with unknown phases.
7. For coherent FSK signals to be orthogonal, the FSK frequencies must be integer multiple of  $1/(2T_s)$  and their separation must be a multiple of  $1/(2T_s)$ .  
The null-to-null bandwidth for coherent FSK is:  $B_{\text{null}} = (M + 3)R_s/2$ , Hertz.
8. For noncoherent FSK signals to be orthogonal, the FSK frequencies must be integer multiple of  $1/(2T_s)$  and their separation must be a multiple of  $1/T_s$ .  
The null-to-null bandwidth for noncoherent FSK is:  $B_{\text{null}} = (M + 1) R_s$ , Hertz.
9. Thus, for the same symbol rate:  $R_s$ , more system bandwidth is required for noncoherently detected FSK than for coherently detected FSK.

# Probability of Bit Error: Binary Modulations

## Noncoherent BFSK, Coherent BFSK and Coherent BPSK

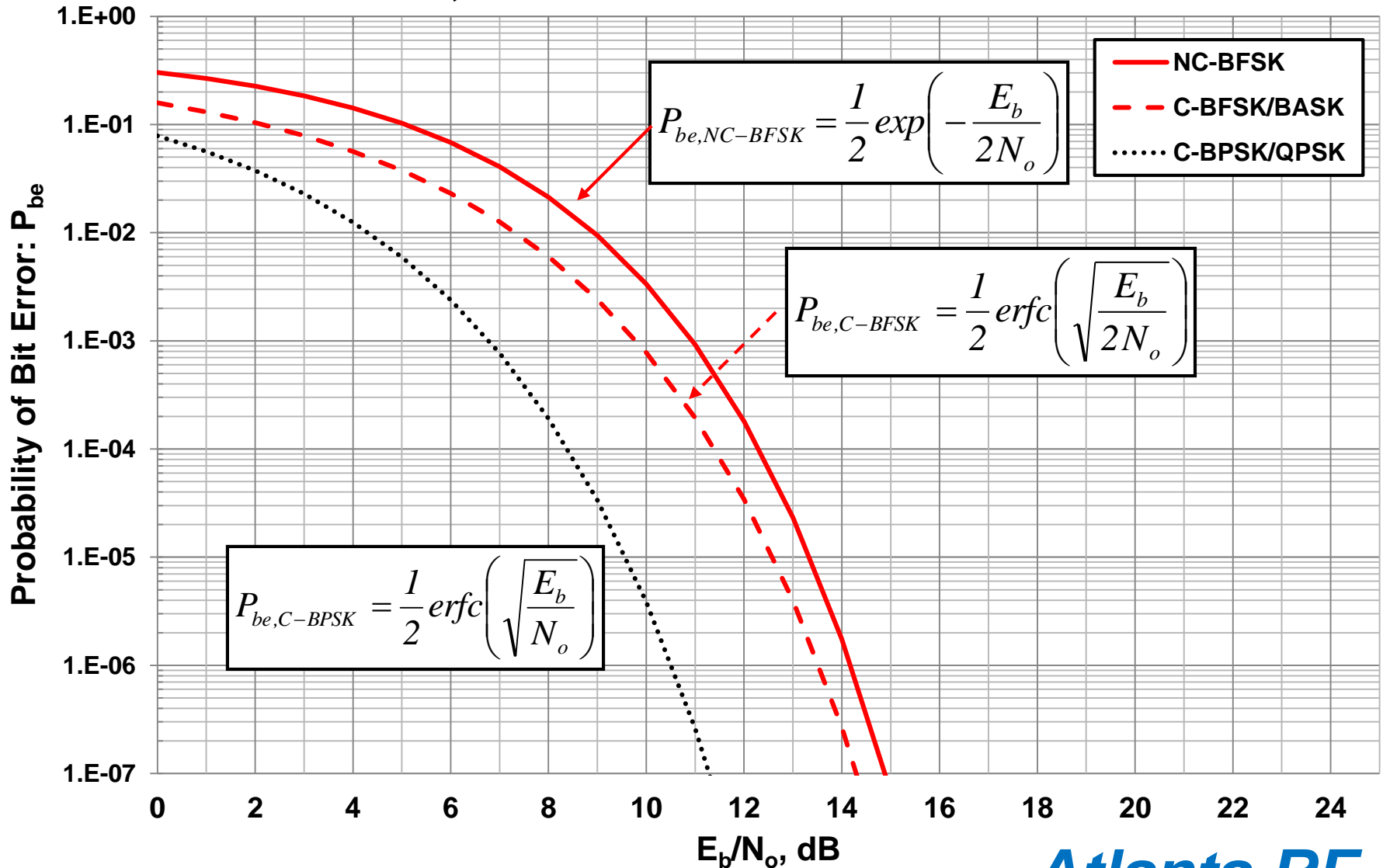

$E_b/N_o$  = Signal energy per bit over Noise density per bit



# Probability of Bit Error (BER): Non-Coherent MFSK

## In an Additive White Gaussian Noise (AWGN) channel

Probability of bit error (BER) expression for non-coherently demodulated, equi-probable, equal-energy and orthogonal *Multi-Level FSK* is:

$$P_{be,NC-MFSK} = \left( \frac{M/2}{M-1} \right) \sum_{n=1}^{M-1} \frac{(-1)^{n+1} \binom{M-1}{n}}{n+1} \exp\left( -\frac{n(\log_2 M)E_b}{(n+1)N_o} \right)$$

k, bits/ symbol =		1	2	3	4
M signal levels =		2	4	8	16
$E_b/N_o$ , dB	$E_b/N_o$	Probability of Bit Error:		$P_{be,NC-MFSK}$	
0	1.000	0.30327	0.22934	0.19472	0.17469
1	1.259	0.26644	0.18475	0.14559	0.12169
2	1.585	0.22637	0.13987	0.09919	0.07474
3	1.995	0.18438	0.09772	0.05981	0.03886
4	2.512	0.14240	0.06156	0.03076	0.01625
5	3.162	0.10287	0.03395	0.01288	0.00513
6	3.981	0.06831	0.01579	0.00414	0.00113
7	5.012	0.04080	0.00591	9.55E-04	1.58E-04
8	6.310	0.02132	0.00168	1.44E-04	1.25E-05
9	7.943	0.00942	3.39E-04	1.29E-05	4.94E-07
10	10.000	0.00337	4.44E-05	6.04E-07	8.20E-09
11	12.589	9.23E-04	3.38E-06	1.25E-08	4.64E-11
12	15.849	1.81E-04	1.30E-07	9.46E-11	6.85E-14
13	19.953	2.32E-05	2.16E-09	2.01E-13	1.87E-17
14	25.119	1.76E-06	1.23E-11	8.66E-17	6.08E-22
15	31.623	6.79E-08	1.85E-14	5.02E-21	1.36E-27
16	39.811	1.13E-09	5.13E-18	2.33E-26	1.05E-34
17	50.119	6.54E-12	1.71E-22	4.48E-33	1.17E-43

where :  $k = \log_2 M$ , bits/symbol.

$$E_s = E_b (\log_2 M) = kE_b$$

The binomial coefficient is:

$$\binom{M-1}{n} = \frac{(M-1)!}{(M-1-n)! n!}$$

**8/22/15:** Many thanks to Jim at Harris Corporation for noting that the exponent requires a '-' sign. Just a 'typo-error', since Excel calculations did include that minus sign for  $P_{be,NC-MFSK}$ .

**Atlanta RF**

Services, Software & Designs

# Probability of Bit Error: Non-coherent M-FSK

$$P_{be,NC-MFSK} = \left( \frac{M/2}{M-1} \right) \sum \frac{(-1)^n \binom{M-1}{n}}{n+1} \exp \left( - \frac{n(\log_2 M) E_b}{(n+1) N_o} \right)$$

Probability of Bit Error: P<sub>be,NC-MFSK</sub>

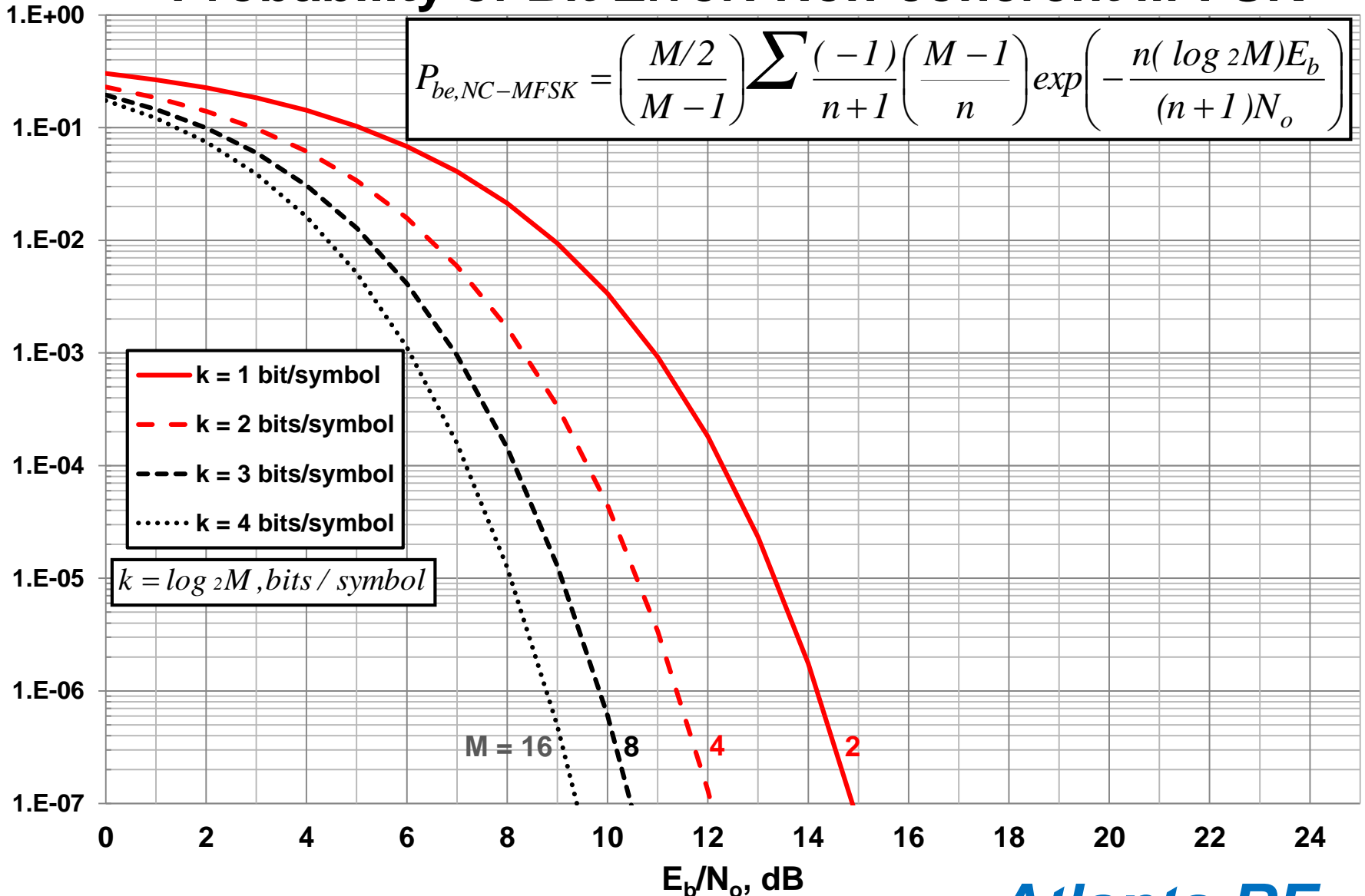

$E_b/N_o$  = Signal energy per bit over Noise density per bit

# Demodulator for Noncoherent Binary FSK

Using spectrally-matched filters and envelope detection

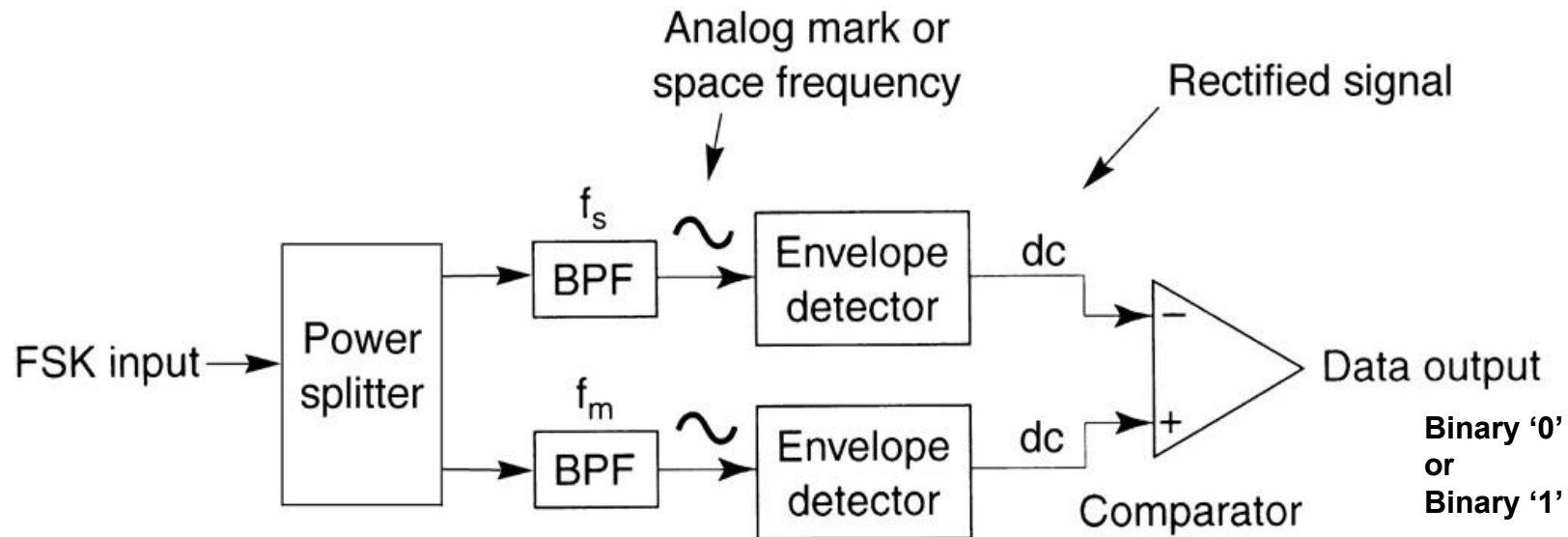

No frequency is involved in the demodulator process that is synchronized either in phase, frequency or both with the incoming FSK signal: No carrier recovery circuits.

# Bandwidth Efficiency: M-FSK

## Coherently detected FSK & Non-coherently detected FSK

1. The Null-to-Null RF transmission bandwidth for MFSK with square baseband pulses:
  - A.  $B_{\text{null}} = R_s + (M - 1)(f_2 - f_1) + R_s = 2R_s + (M - 1) 2\Delta f$ , where:  $R_s = f_b/N$ ,  $N = \log_2 M$ .
  - B. For coherently detected M-FSK:  $2\Delta f_{\text{min}} = R_s/2$ . Then,  $B_{\text{null}} = (M + 3)R_s/2$ , Hertz.
  - C. For non-coherently detected M-FSK:  $2\Delta f_{\text{min}} = R_s$ . Then,  $B_{\text{null}} = (M + 1) R_s$ , Hertz.  
where :  $k = \log_2 M$ , bits/symbol.

2. Bandwidth (Spectral) Efficiency for any modulation :  $\eta_B = \frac{R_b}{B_T}$ , bits/second/Hz

Modulation Format	M Levels	k, bits per symbol	Coherent FSK		Non-coherent FSK	
			Null-to-Null Bandwidth	Spectral Efficiency	Null-to-Null Bandwidth	Spectral Efficiency
BFSK	2	1	$(5/2) R_b = 2.5R_b$	$2/5 = 0.4$	$3 R_b$	$1/3 = 0.33$
QFSK	4	2	$(7/4) R_b = 1.75 R_b$	$4/7 = 0.57$	$(5/2) R_b = 2.5 R_b$	$2/5 = 0.40$
8-FSK	8	3	$(11/6) R_b = 1.83 R_b$	$6/11 = 0.54$	$3 R_b$	$1/3 = 0.33$
16-FSK	16	4	$(19/8) R_b = 2.37 R_b$	$8/19 = 0.42$	$(17/4) R_b = 4.25 R_b$	$4/17 = 0.23$
32-FSK	32	5	$(35/10) R_b = 3.5 R_b$	$10/35 = 0.29$	$(33/5) R_b = 6.6 R_b$	$5/33 = 0.15$
64-FSK	64	6	$(67/12) R_b = 5.6 R_b$	$12/67 = 0.18$	$(65/6) R_b = 10.8 R_b$	$6/65 = 0.09$

# Carrier-to-Noise Ratio for M-FSK at BER values

## Coherently detected MFSK & Non-Coherently detected MFSK

Modulation Format	M Levels	k, bits per symbol	Coherent FSK					Non-Coherent FSK				
			Carrier-to-Noise Ratio: Eb/No					Carrier-to-Noise Ratio: Eb/No				
			BER 10 <sup>-4</sup>	BER 10 <sup>-6</sup>	BER 10 <sup>-8</sup>	BER 10 <sup>-10</sup>	BER 10 <sup>-12</sup>	BER 10 <sup>-4</sup>	BER 10 <sup>-6</sup>	BER 10 <sup>-8</sup>	BER 10 <sup>-10</sup>	BER 10 <sup>-12</sup>
BFSK	2	1	11.4dB	13.5dB	15dB	16dB	16.9dB	12.3dB	14.1dB	15.4dB	16.5dB	17.3dB
QFSK	4	2	8.7dB	10.7dB	12.1dB	13.2dB	14dB	9.6dB	11.4dB	12.6dB	13.6dB	14.4dB
8-FSK	8	3	7.3dB	9.2dB	10.5dB	11.5dB	12.3dB	8.1dB	9.8dB	11dB	12dB	12.7dB
16-FSK	16	4	6.5dB	8.2dB	9.4dB	10.4dB	11.2dB	7.2dB	8.8dB	9.9dB	10.8dB	11.6dB
32-FSK	32	5	5.8dB	7.5dB	8.6dB	9.6dB	10.4dB					
64-FSK	64	6	5.3dB	6.8dB	8dB	8.9dB	9.7dB					

FSK Demodulation (Coherent)

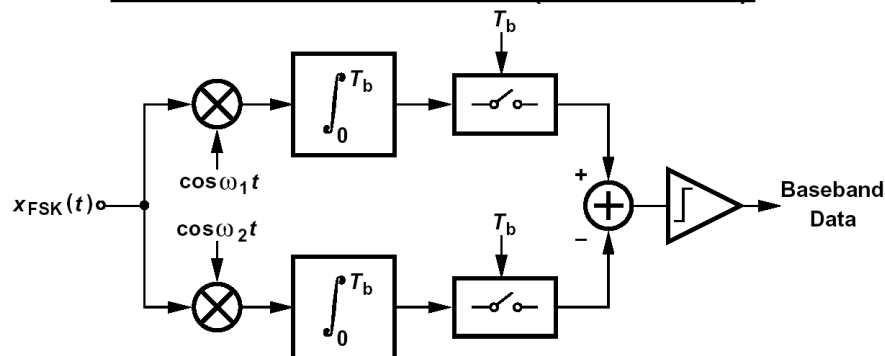

FSK Demodulation (Non-Coherent)

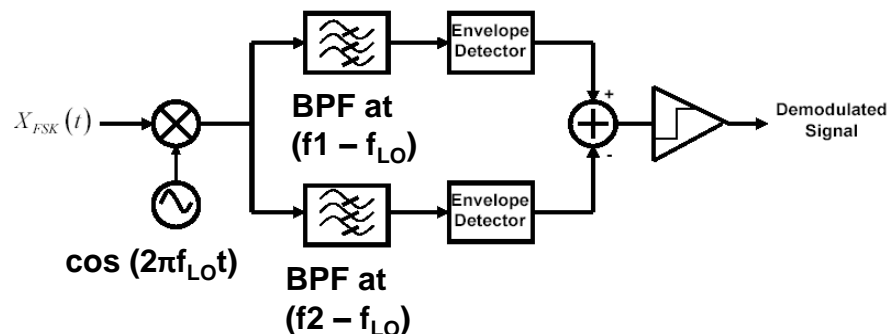

**Atlanta RF**

Services, Software & Designs

# MSK: Minimum (frequency) Shift Keying

## Overview

1. *Minimum frequency-shift keying or minimum-shift keying* (MSK) is a special type of continuous phase-frequency shift keying (CPFSK), where the frequency changes occur at the carrier zero crossings.
2. MSK is sometimes referred to as 'fast FSK', as the frequency spacing used is only half as much as that used in conventional non-coherent FSK.
3. A MSK signal also can be thought of as a special form of Offset QPSK where the baseband rectangular pulses are replaced with half-sinusoidal pulses.
4. MSK is a particularly spectrally efficient form of coherent binary FSK. In MSK, the difference between the higher & lower frequency is identical to half the bit rate:  $2\Delta f = (f_H - f_L) = R_b/2 = 1/(2T_b)$ . . . . Or:  $\Delta f = R_b/4 = 1/(4T_b)$ .
5. As a result, the waveforms used to represent a '0' bit and a '1' bit differ by exactly half a carrier period. This is the smallest FSK [modulation index](#) that can be chosen such that the waveforms for '0' and '1' are [orthogonal](#). Orthogonality guarantees that both signals will not interfere with each other during the detection process and create the minimum spectral bandwidth.
6. The carrier frequency of a MSK signal is:  $f_2 = f_c + 1/(4T_b)$  or  $f_1 = f_c - 1/(4T_b)$ .
7. The carrier's frequency:  $f_0 = (m/4) f_b$  is an integral multiple of  $f_b/4$ .
8. A variant of MSK called: [GMSK](#) is used in the [GSM mobile phone](#) standard.

# MSK: Minimum Shift Keying

## Basis of Operation

1. For MSK modulation, the phase change ramps up or down linearly in time over a bit interval:  $T_b$  and is limited to  $\pm \pi/2$  ( $\pm 90^\circ$ ). Phase can only be  $\pm \pi/2$  at odd multiples of  $T_b$ , and  $0^\circ$  or  $\pi$  at even multiples of  $T_b$ . This enables MSK to provide a significant improvement over QPSK. The binary MSK-modulated transmitted signal is given by:

$$s(t)_{MSK} = \sqrt{\frac{2E_b}{T_b}} \cos[2\pi f_c t + \theta(t)] = \begin{cases} \sqrt{\frac{2E_b}{T_b}} \cos[2\pi f_1 t + \theta(0)] & \text{for binary "1"} \\ \sqrt{\frac{2E_b}{T_b}} \cos[2\pi f_2 t + \theta(0)] & \text{for binary "0"} \end{cases}$$

where:  $\theta(t) = \theta(0) \pm \frac{\pi h}{T_b} t$ , and  $h = T_b(f_1 - f_2) = 2\Delta f T_b$  is the modulation index.

2. MSK uses changes in phase to represent 0's and 1's, but unlike most other keying, the pulse sent to represent a 0 or a 1, not only depends on what information is being sent, but what was previously sent. From the above equation,  $\theta(t)$  depends not only on the symbol being sent (from the change in the sign), but also depends on  $\theta(0)$ , which means that the pulse also depends on what was previously sent (= embedded memory).

# Minimum Shift Keying (MSK) Waveform: Example

MSK  
modulated  
Signal:  $S(t)$

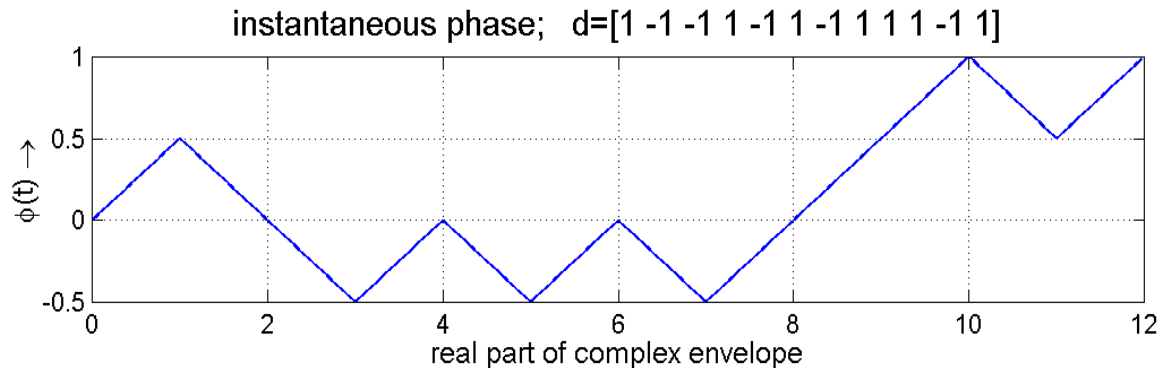

In-phase  
Component

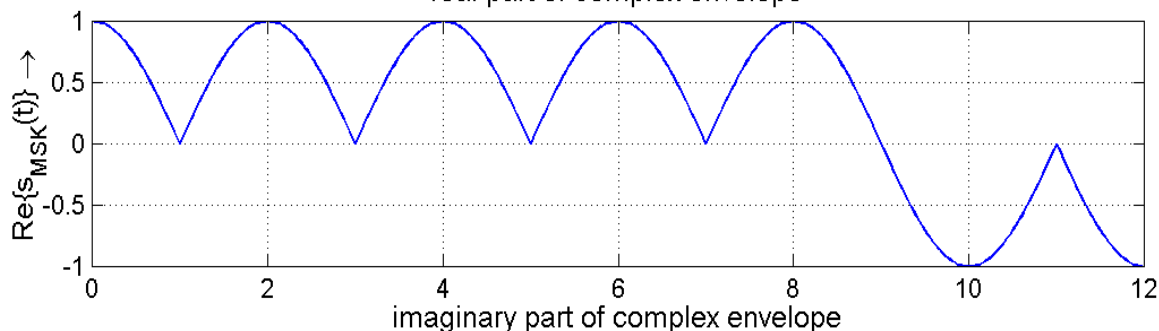

Quadrature-phase  
Component

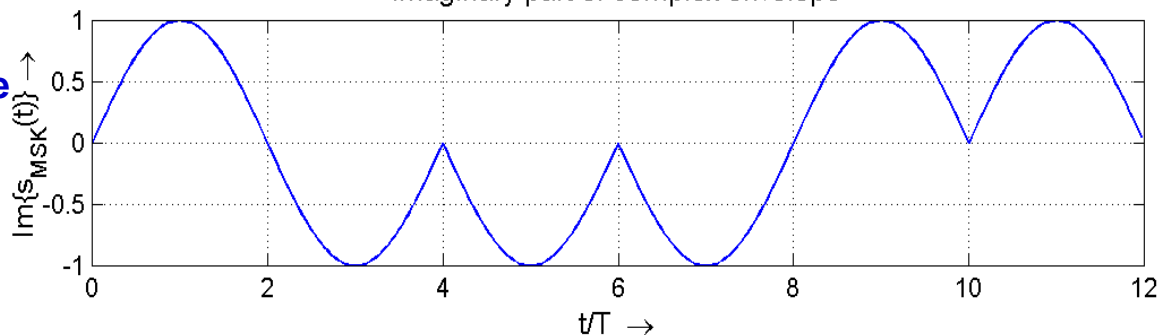



# Bandpass Power Spectral Density of MSK

Assumes baseband rectangular pulses: 

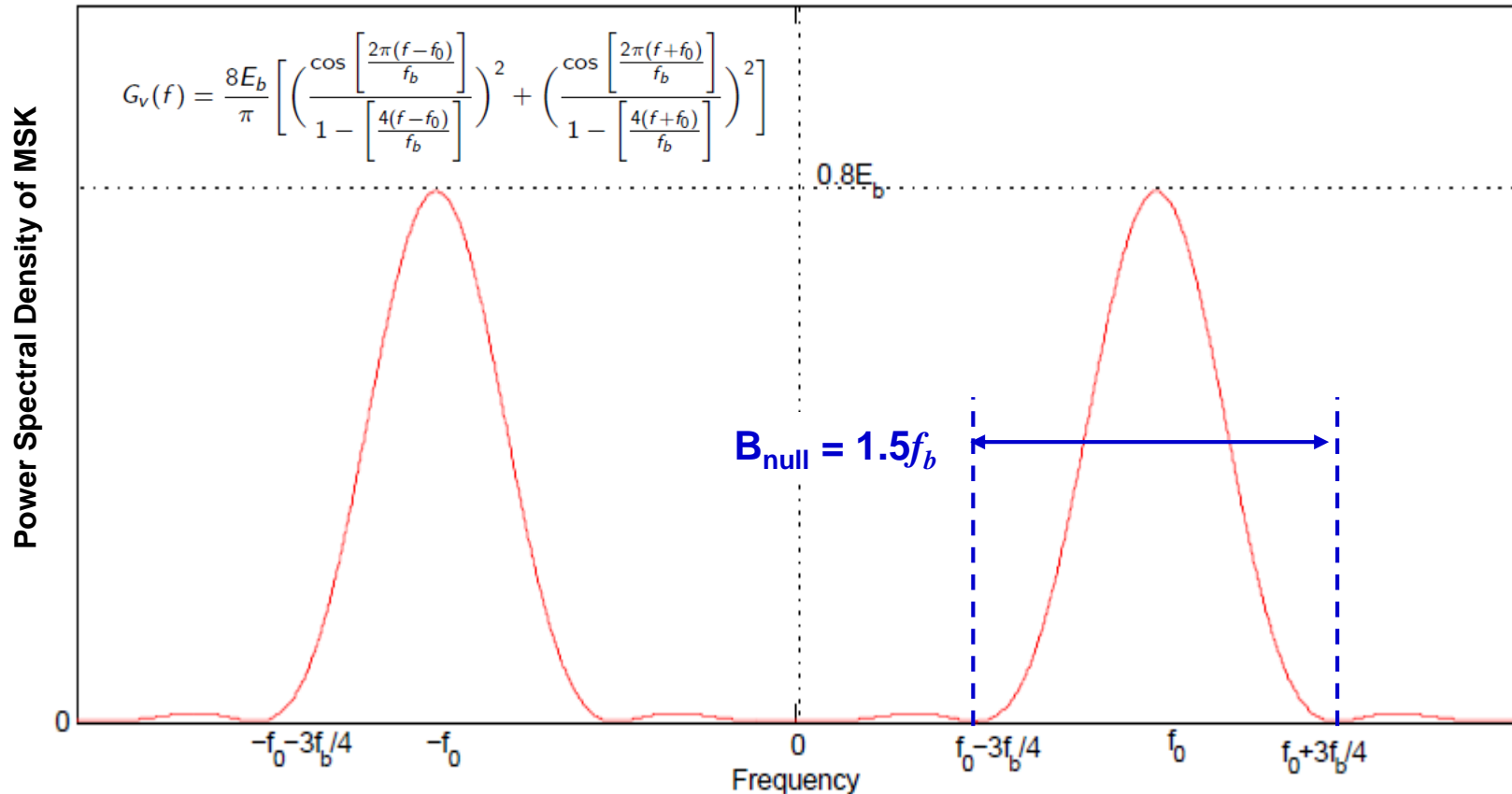

- The Null-to-Null RF bandwidth of MSK:  $B_{\text{null}} = (f_0 + 3f_b/4) - (f_0 - 3f_b/4) = 3f_b/2 = 1.5f_b$ .
- 99% of the mean signal power of MSK is contained in a bandwidth of  $\sim 1.17f_b$ .
- Spectral efficiency of MSK:  $\eta = R_b/B = R_b/(1.5f_b) = 0.667$  bits/second/Hertz.

**Atlanta RF**

Services, Software & Designs

# Features of MSK Modulation

## 1. Advantages of MSK Modulation:

- A. Since the MSK signals are orthogonal and with a minimal frequency spacing/distance, the frequency spectrum can be more compact.
- B. The detection scheme can take advantage of the orthogonal characteristics.
- C. MSK modulation has low Inter-Symbol Interference (ISI), compared to Gaussian MSK: GMSK.

## 2. Disadvantages of MSK Modulation:

- A. The fundamental problem with MSK is that the spectrum has side-lobes (i.e.: RF signal power) extending well above the data rate.
- B. For wireless systems, which require more efficient use of RF channel bandwidth, it is necessary to reduce the energy of the upper side-lobes.
- C. Solution: Use a pre-modulation filter to reduce RF energy in side-lobes.
  - 1) Straight-forward approach: Use a Low-Pass Filter.
  - 2) More efficient/realistic approach: Use a Gaussian Low-Pass Filter.

# Normalized Power Spectral Density for BPSK, QPSK, O-QPSK, and MSK

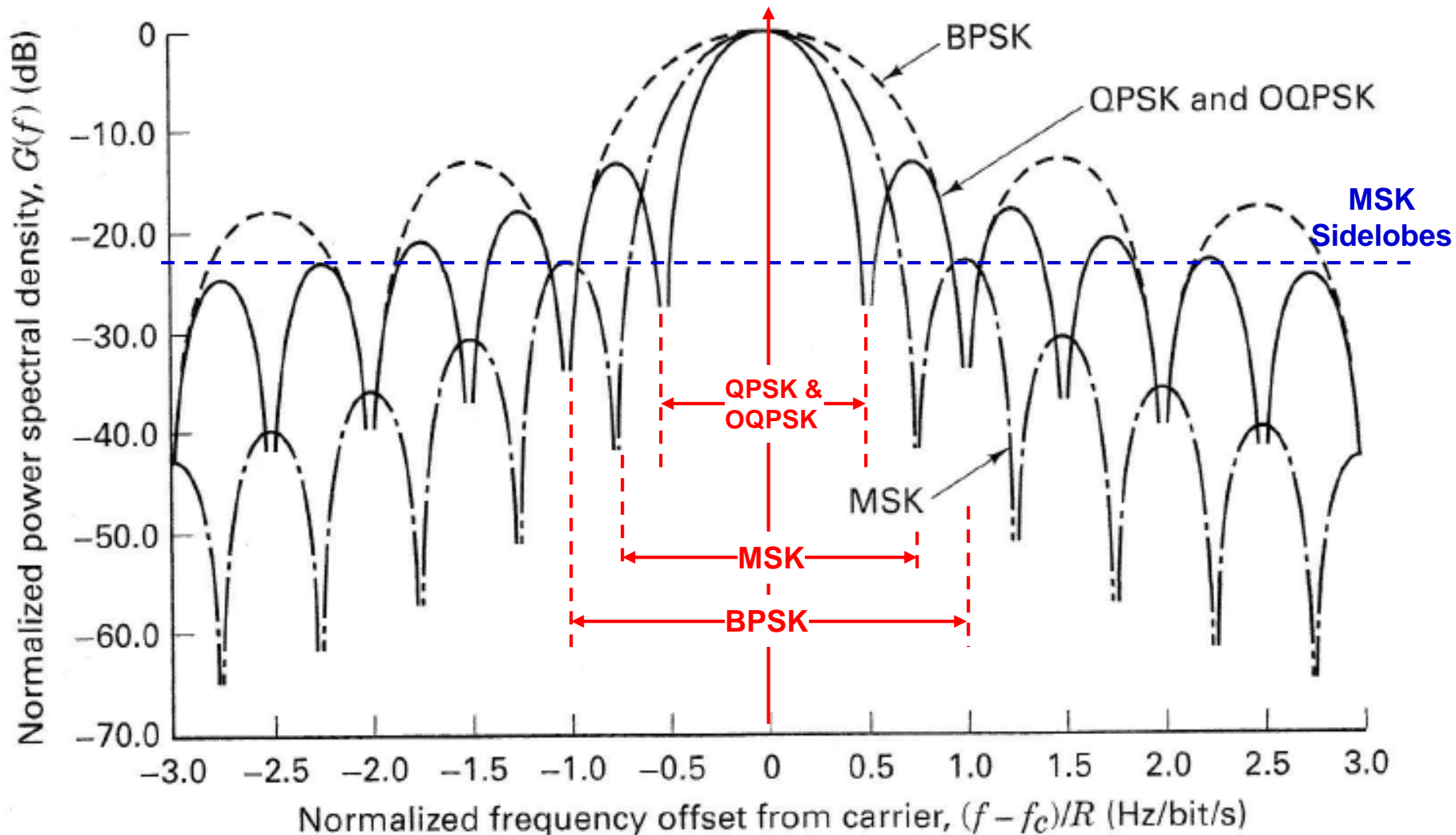

**Atlanta RF**

Services, Software & Designs

# Error Performance of QPSK, O-QPSK, and MSK

1. Binary PSK and Quadrature PSK have the same bit-error probability because QPSK is configured as two Binary PSK signals modulating orthogonal components of the carrier.
2. Since staggering the bit streams does not change the orthogonality of the carriers, Offset-QPSK has the same theoretical bit error performance as BPSK and QPSK.
3. MSK uses antipodal symbol shapes:  $\pm \cos(\pi t/2T)$  and  $\pm \sin(\pi t/2T)$ , over  $2T_b$ , thus when a matched filter is used, MSK has the same bit-error performance.
4. However, if MSK is coherently detected as FSK, it would be poorer than Binary PSK by 3dB (MSK can also be non-coherently detected).
5. As such, the average probability of bit error in terms of  $E_b/N_0$  for coherently detected **BPSK**, **QPSK**, **Offset-QPSK** and **MSK** in an additive white Gaussian noise (AWGN) channel is the same:

$$P_{be,BPSK} = Q\left(\sqrt{\frac{2E_s}{N_o}}\right) = Q\left(\sqrt{\frac{2E_b}{N_o}}\right) = \frac{1}{2} \operatorname{erfc}\left(\sqrt{\frac{E_b}{N_o}}\right)$$

# Advantages: MSK and QPSK

1. A MSK modulated signal has continuous phase in all cases, while a QPSK modulated signal has phase shifts of  $\pi$  or  $\pi/2$ .
2. MSK signal does not have amplitude variations.
3. 99% of MSK power is in main lobe. QPSK: 90%.
4. MSK modulated signals have lower side-lobes (-23dB) than QPSK signals (-10 dB). Hence inter-channel interference (ICI) is significantly larger in QPSK modulated signals.
6. To avoid ICI, QPSK requires filtering, which can change the amplitude and phase of the QPSK waveform. Not required for MSK modulation.
7. Distance between signal points is the same in QPSK and MSK. Probability of bit error in an additive white Gaussian noise channel (AWGN) is also the same:

$$P_{be,MSK} = Q\left(\sqrt{\frac{2E_b}{N_o}}\right) = \frac{1}{2} \operatorname{erfc}\left(\sqrt{\frac{E_b}{N_o}}\right)$$

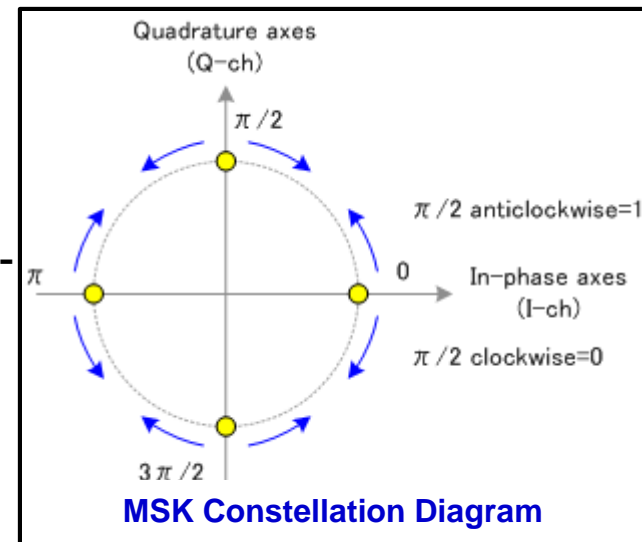

# Disadvantages : MSK and QPSK

1. Null-to-Null RF transmission bandwidth of MSK is:  $B_{\text{null}} = 1.5f_b$  , which is 50% larger than the null-to-null bandwidth for QPSK, which is  $B_{\text{null}} = f_b$  .
2. However, MSK can transmit 99% of the signal power within a bandwidth of  $1.2f_b$  . QPSK requires around  $8f_b$  to transmit the same signal power.
3. Generation and detection of a MSK modulated signal is slightly complex.
4. Phase jitter may be present in MSK because of incorrect synchronization, which can degrade performance.
5. Main lobe of MSK is wide. Unsuitable for applications where extremely narrow bandwidths and sharp cut-offs are required.
6. Slow decay of MSK's Power Spectral Density can create adjacent inter-channel interference: ICI. As such, MSK modulation is not suitable for multi-user communications, but can be overcome using Gaussian MSK: GMSK.
7. Block diagram of a MSK Transmit Modulator:

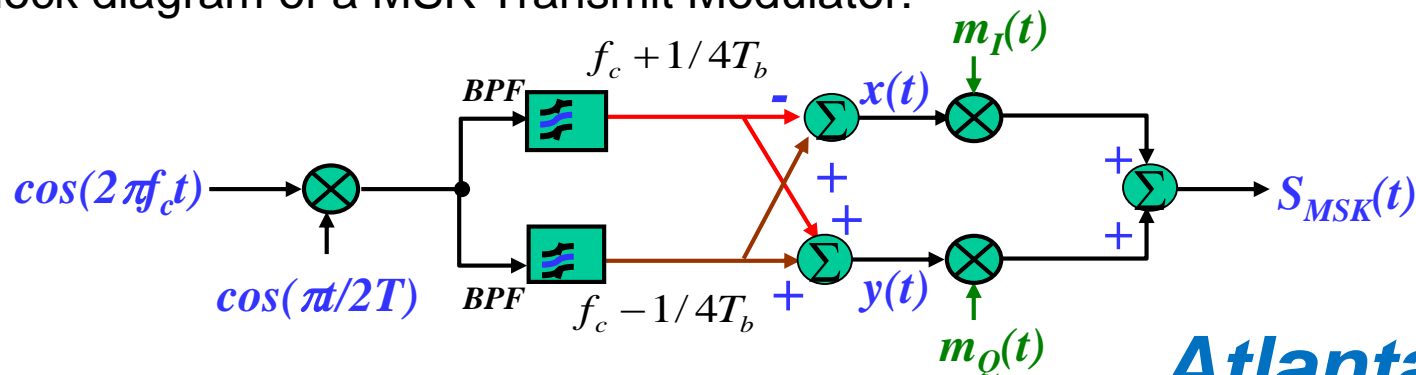

# GMSK: Gaussian Minimum Shift Keying

## Basis of Operation

1. Gaussian Minimum Shift Keying is a continuous-phase frequency-shift keying (CPFSK) modulation technique, similar to standard **Minimum-Shift Keying** (MSK).
2. However, the digital message data stream:  $m(t)$  is first shaped with (passed thru) a pre-modulation linear Gaussian lowpass filter, which smoothes the phase trajectory of the MSK signal, before being applied to a frequency modulator. This has the advantage of reducing side-band power, which reduces out-of-band interference between signal carriers in adjacent frequency channels (i.e.: lower side-lobe RF power levels).

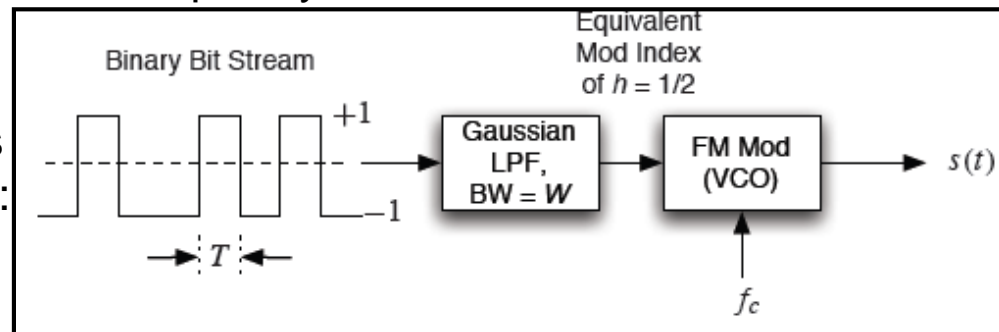

3. As the bandwidth of the Gaussian lowpass filter is lowered, the amount of *Inter-Symbol Interference* (ISI) increases.
4. The degree of filtering is expressed by multiplying the filter's baseband 3dB bandwidth ( $B_{3dB}$ ) by the bit period of the transmission ( $T_b$ ), i.e. by  $B_{3dB}T_b$ .
5. With GMSK modulation, power-efficient (~90%) class-C non-linear amplifiers can be used; however, even with a low  $B_{3dB}T_b$  value, its bandwidth efficiency is less than filtered QPSK.

# GMSK Modulation: Example

## GMSK modulation Eye-pattern and Waveform

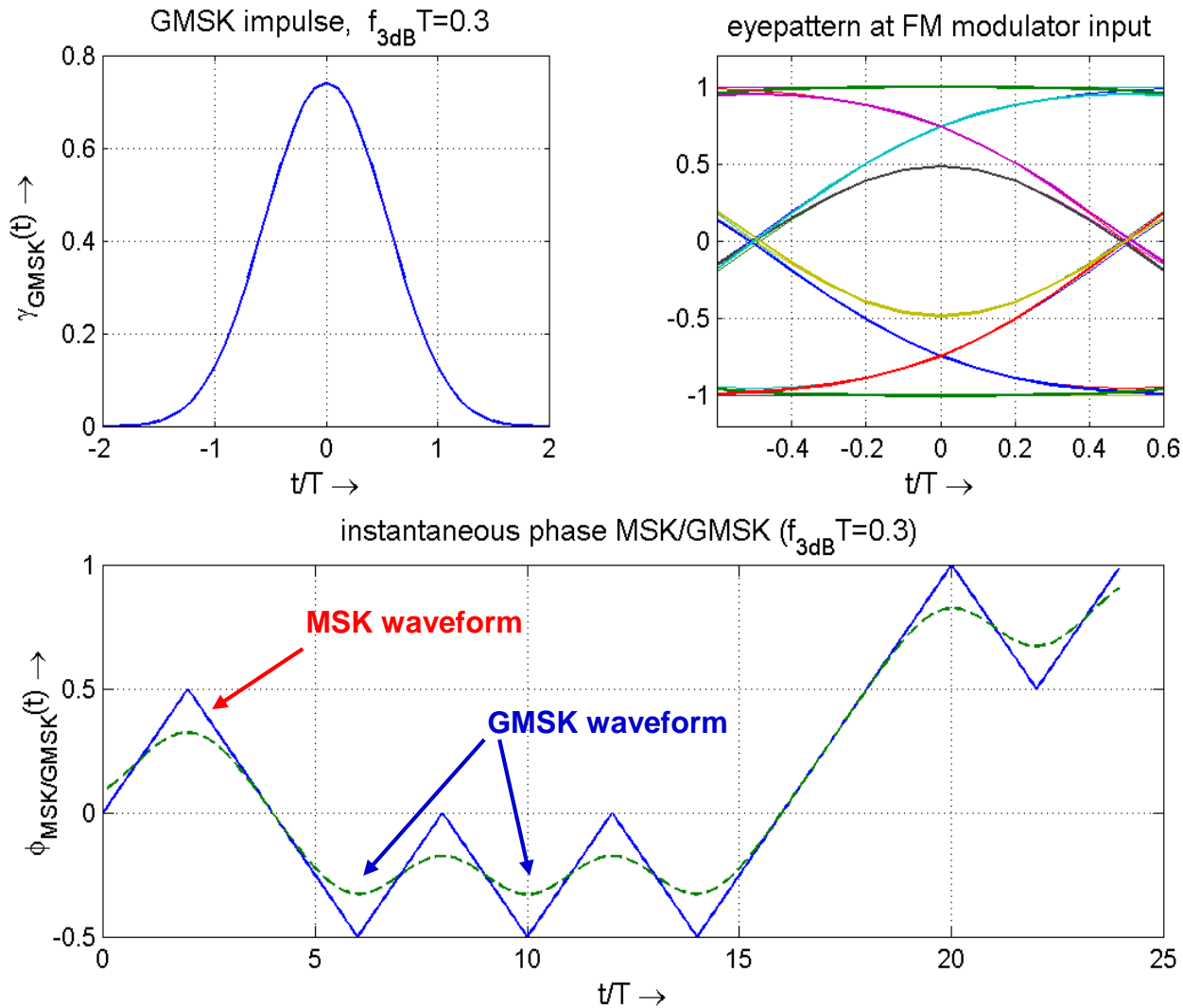



# Block Diagram for **GMSK** Modulation

## 1. Generating GMSK using VCO-FM Modulation Method:

A. Using analog (frequency) modulation (FM).

B. Influenced by modulator's sensitivity & linearity of Voltage-Controlled Oscillator (VCO).

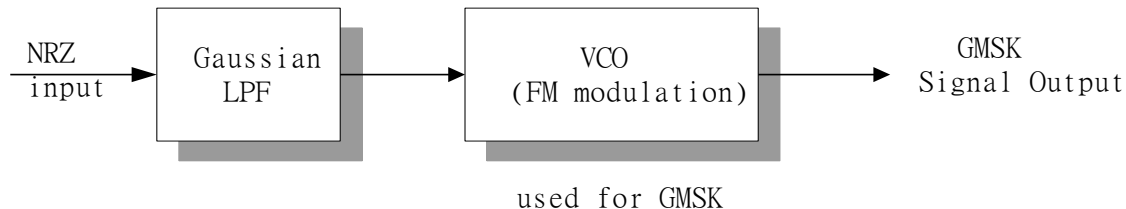

## 2. Generating GMSK using a 'Look-up Table' Method:

A. Using an 'all digital' baseband transmitter.

B. Method is suitable for use in a software-defined radio.

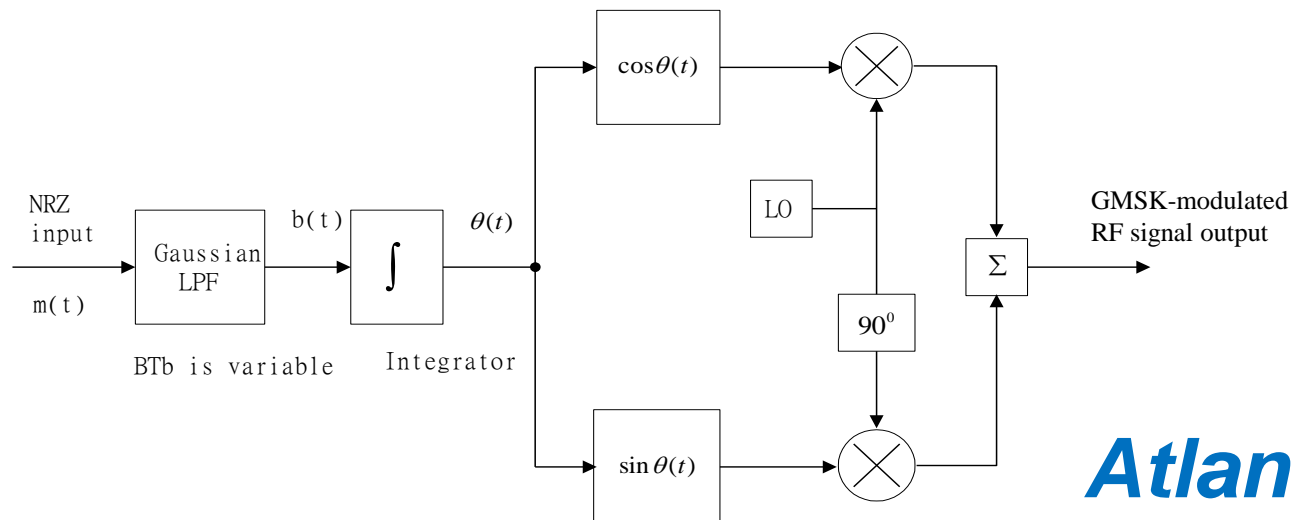

# BER of **GMSK** for AWGN channel

1. The bit error rate: BER, for a baseband signal modulated with binary Gaussian Minimum Shift Keying: GMSK in an additive white Gaussian noise (AWGN) environment is influenced by the Gaussian pulse-shaping filter, which causes Inter-Symbol Interference: ISI, so its probability of bit error is a function of its Time-Bandwidth product:  $B_{3dB}T_b$  as:

$$P_{e, GMSK} = Q\left(\sqrt{\frac{2\lambda E_b}{N_0}}\right) = \frac{1}{2} \operatorname{erfc}\left(\sqrt{\frac{\lambda E_b}{N_0}}\right)$$

where:  $\lambda$  is a constant related to  $B_{3dB}T_b$  :

- For  $B_{3dB}T_b = 0.25$  , then  $\lambda = 0.68$
- For  $B_{3dB}T_b = \infty$  , then  $\lambda = 0.85$

# GMSK Power Spectra Comparison: Example

## PSD of QPSK, MSK and GMSK modulations

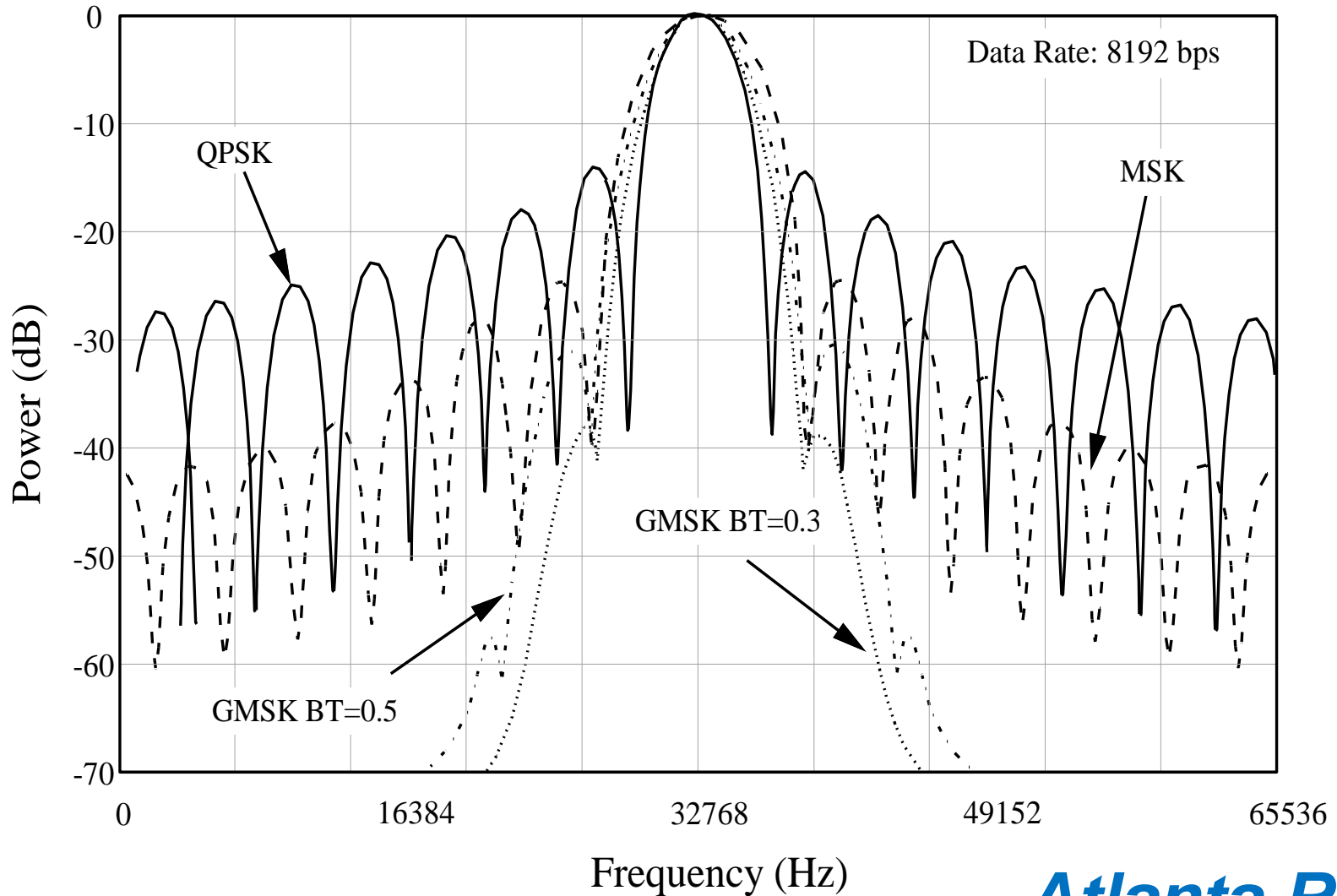

# GMSK: Power versus Bandwidth

RF bandwidth containing 'X' percent RF power as a fraction of  $R_b$

$B_{3dB}T_b$	90%	99%	99.9%	99.99%
0.2 GMSK	$0.52R_b$	$0.79R_b$	$0.99R_b$	$1.22R_b$
0.25 GMSK	$0.57R_b$	$0.86R_b$	$1.09R_b$	$1.37R_b$
0.5 GMSK	$0.69R_b$	$1.04R_b$	$1.33R_b$	$2.08R_b$
MSK	$0.78R_b$	$1.20R_b$	$2.76R_b$	$6.00R_b$

← Percent RF power

Bandwidth containing RF power

For example:

For  $B_{3dB}T_b = 0.2 \rightarrow$  99.99% of the power is contained in the bandwidth of  $1.22R_b$

BER degradation from Inter-Symbol Interference (ISI) caused by GMSK filtering is minimal at  $B_{3dB}T_b = 0.5887$ .

- Degradation in required  $E_b/N_0 = 0.14\text{dB}$ , compared to the case of no ISI.

# GMSK Application: Mobile Communication

1. Binary GSMK modulation is used extensively in 2<sup>nd</sup> generation digital cellular and cordless telephone applications:
  - A. GMSK modulation (with  $B_{3dB}T_b = 0.3$ ) is used in **GSM** (Global System for Mobile communication) that transmits a Data Rate:  $R_b = 270.833$  kbps in a signal bandwidth:  $B_T = 200$ kHz per channel, which results in a Spectral Efficiency:  $\eta_B = R_b/B_T = 1.35$ bits/sec/Hz (= 270kb/s/200kHz). The pre-modulation Gaussian filter has a 3dB bandwidth:  $B_{3dB} = 81.25$  kHz, which produces a Time-Bandwidth product:  $B_{3dB}T_b = 81.25$ kHz/270.8kHz = 0.3 used in GSM cellular systems.
  - B. GMSK modulation (with  $B_{3dB}T_b = 0.5$ ) is used in **DECT** (Digital European Cordless Telephone) that transmits a gross Date Rate:  $R_b = 1152$ kbps in a signal bandwidth:  $B_T = 1728$ kHz, which results in a Bandwidth Efficiency:  $\eta_B = R_b/B_T = 0.67$  bps/Hz (1152k1728k). The pre-modulation Gaussian filter has a 3dB bandwidth:  $B_{3dB} = 576$  kHz, which produces a Time-Bandwidth product:  $B_{3dB}T_b = 576$ kHz/1152kbps = 0.5 used in DECT cellular systems.
  - C. For  $B_{3dB}T_b = 0.3$  (GSM standard), adjacent symbols will interfere with each other more than for  $B_{3dB}T_b = 0.5$  (DECT standard).
2. Ninety-nine percent (99%) of the RF power of GMSK signals is specified to be confine to 250kHz (+/- 25kHz margin from the signal), which means that the sidelobe's RF signal power levels need to be virtually zero outside this frequency band, and the Inter-Symbol Interference (ISI) should be negligible.

# Summary: Digital Modulation, Part 2

## Multi-Level Frequency Shift Keying: $M$ -ary FSK

1. Digital Modulation continues to dominate the world of data & voice communication with high throughput within a congested frequency spectrum at affordable cost.
2. Frequency Shift Keying (FSK) is a constant-envelope modulation technique, so power-efficient class-C power amplifiers can be used.
  - A. FSK is not very susceptible to degradation caused by noise.
3. A variant of binary FSK: Gaussian Minimum Shift Keying (GMSK) offers low signal energy outside the RF transmission bandwidth (low adjacent-channel interference) and is used extensively in cellular communications.
4. Look for additional presentations from *Atlanta RF* on Digital Modulation techniques, and visit our website: [www.AtlantaRF.com](http://www.AtlantaRF.com) to download these and other topics on Link Budget Analysis.

Refer to background material in Atlanta RF's presentations titled:

1. 'Link Budget – Getting Started' and
2. 'Link Budget: Digital Modulation Part 1'

which can be downloaded from our website: [www.AtlantaRF.com](http://www.AtlantaRF.com).

**Atlanta RF**

Services, Software & Designs



## Atlanta RF

*Services, Software & Designs*

Atlanta RF LLC was founded to provide engineering solutions, design software solutions, and product development solutions to the high-frequency RF/microwave industry in the areas of: Telecommunications (ground segment), Satellite (space segment) and military/defense (RF front-ends).

Through teamwork, Atlanta RF applies our diverse technical experience to your project's challenges with creative and innovative solutions while holding ourselves accountable for the results. With professionalism and commitment to our clients, Atlanta RF will be there for you, both today and tomorrow.

Contact Atlanta RF by e-mail at:

- Atlanta RF **Services** : [Services@AtlantaRF.com](mailto:Services@AtlantaRF.com)
- Atlanta RF **Software** : [Sales@AtlantaRF.com](mailto:Sales@AtlantaRF.com)
- Atlanta RF **Designs** : [Designs@AtlantaRF.com](mailto:Designs@AtlantaRF.com)

Or, contact Atlanta RF by phone at: 678-445-5544, to reach our Atlanta-area office in Georgia, USA, and discuss our support to your current or future projects & products.

**Atlanta RF**

*Services, Software & Designs*

# Presentations by Atlanta RF, LLC

Download various presentations at our website: [www.AtlantaRF.com](http://www.AtlantaRF.com) :

1. Satellite: LEO, MEO & GEO.
2. Antennas: An Overview.
3. Link Budget: Getting Started.
4. Link Budget: Digital Modulation Part 1 (Overview & M-ASK).
5. Link Budget: Digital Modulation Part 2 (M-FSK).
6. Link Budget: Digital Modulation Part 3 (M-PSK & QAM).
7. Link Budget: Error Control & Detection.
8. Multiple Access Techniques: FDMA, TDMA and CDMA.
9. Insertion Loss: Double Ridge Waveguide.
10. RF Filters: An Overview.
11. Multi-Section Symmetrical Directional Couplers.
12. Parallel Coupled Bandpass Filters.

Visit our website often as presentations are added for your viewing pleasure.

**Atlanta RF**

Services, Software & Designs